



Ultrahigh-Speed Three-Side-Seal Pouch Forming, Filling and Packaging Machines

# R-series **S-type** **G-type**

**NEW**

**Servomotor-equipped machines**

**R-35S**

**R-36S**

**R-51S**

**R-52S**



The photo shows the R-52S model.



The photo shows the R-35G model.

**Rotary machines**

**R-35G**

**R-36G**

**R-51G**

**R-52G**

# R-series S-type G-type

# High-Speed Three-Side-Seal Pouch Forming, Filling and Packaging Machines

Simpler structure, more compact, more reasonably priced than ever

## Features

- The rotary system performs pouch forming, filling and sealing operations in a horizontal direction to achieve an ultra-fast packaging rate of 300 to 600 pouches per minute. Since a longer filling time can be provided, there is minimal biting of the filling product at the sealed areas. In addition, the sealing time can be extended and pinhole generation can be reduced.
- Use of the optional stacker allows connection of a cartoner, flow wrapper, banding unit and pouch filler.
- Various accessories and optional devices are available to meet specific packaging needs.

## A wealth of new mechanisms

- Equipped with Topack's proprietary servo system (patent pending) <S type>
  - The cutter-drive servomotor control minimizes the positional deviation of the cutter.
  - The top sealer drive servomotor control eliminates the need to change gears and numerical settings can be entered easily on the touch panel.
- Easy-to-operate touch panel <S type>
  - The standard 5.7-inch color touch panel displays auto-stop record and production control data.
- T-1 stacker (patent pending) <S type>
  - The servomotor-controlled elevation mechanism assures stable product stacking.
  - The number of stacking rows can be set easily on the touch panel.



- New automatic film splicer
  - Two film rolls mounted on the right and left sides allow uniform film tension for added stability in automatic film splicing operation.
  - The low film loading position enables the use of film rolls measuring up to 400 mm in diameter.
- Compact dimensions
  - The compact machine size requires about 20% less installation space than a conventional unit.
- New rotary mechanism (patent pending)
  - The seal bar cam and chute up/down cam feature Topack's original cam profiles to allow precision processing.
  - Smooth rotation reduces operating noise and prolongs service life.
- Rotary disk shutter ON/OFF control (patent pending)
  - Movable shutter operating pins, operated by an air cylinder, are used in place of conventional fixed pins. All shutters remain closed whenever the rotary disk is not rotating.
    - 1 When the rotary disk is turned on, the shutters open after synchronizing with the filling chute, then the filling operation starts.
    - 2 When the rotary disk is shut off, all the shutters close, then the rotary disc stops. This minimizes splashing of the filling product.
- Magnetic discharge clipper (patent pending)
  - Magnets are used in the clipper in place of springs. When the clipper is open, no load is applied, thus reducing the stress on the clipper opening mechanism and turn section. The new system offers improved durability and also eliminates spring replacement.

- Digital print registration system (patented)  
Equipped on R-36S, R-52S, R-36G and R-52G

- Easy operation with the touch panel.
- All control information is displayed on the touch panel for real-time confirmation of numeric data.
- The photo mark position can be changed with input of numeric data, thus allowing flexible adjustment of the seal position.
- When the pitch control fails, the required amount of seal bar inward/outward movement is numerically displayed.
- Stores data for up to 8 products.

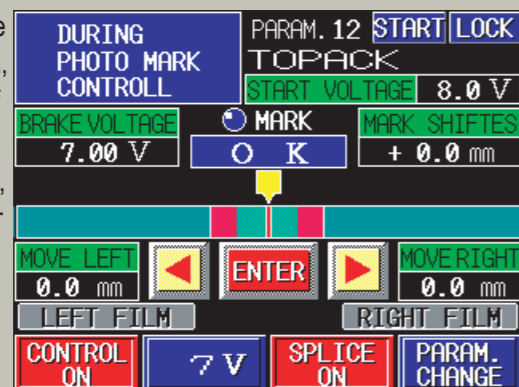

- Stacking mechanism (patent pending)

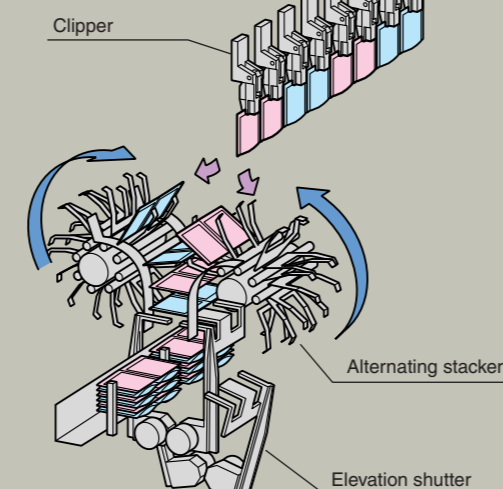

※S-type machines are equipped with the T-1 stacker, which uses servomotor control for the elevation mechanism.

- High-speed filling and sealing mechanisms

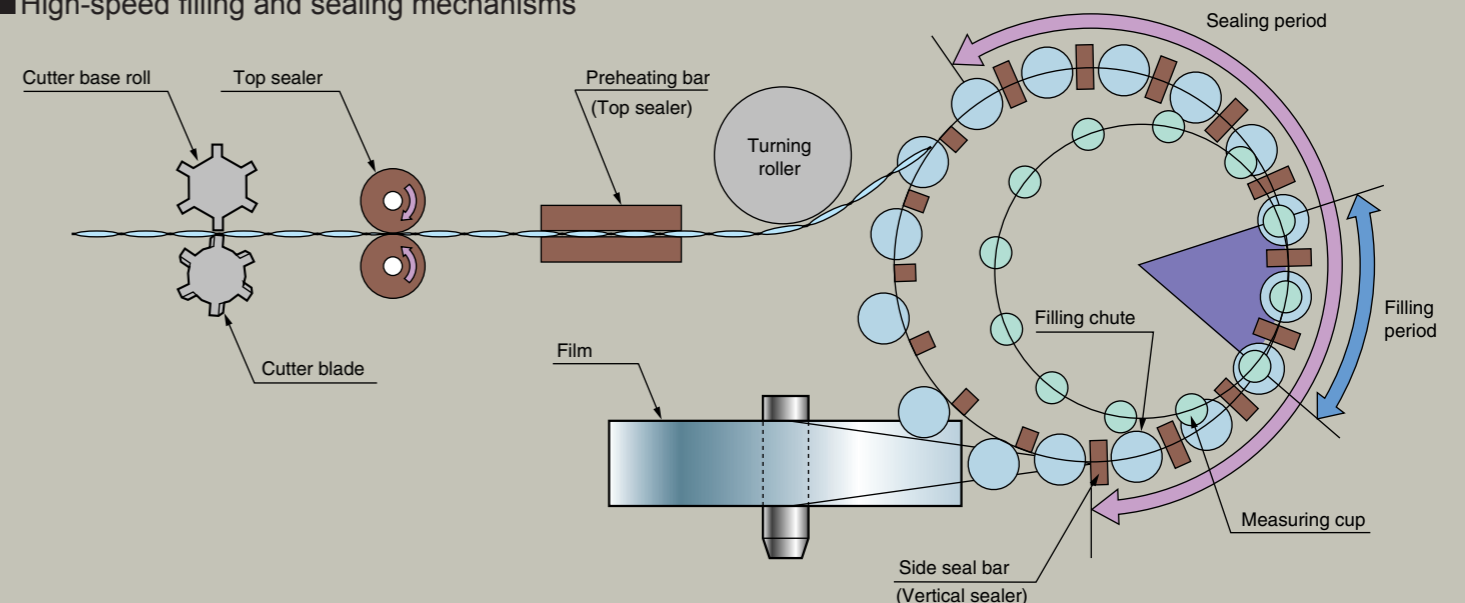

## ■ Main specifications of R-series S-type machines <Servomotor-equipped machines>

Model	Small pouch machine		Large pouch machine	
	R-35S	R-36S	R-51S	R-52S
Print registration control	None	Provided	None	Provided
Filling capacity ※ <sup>1</sup> ※ <sup>2</sup>	0.5 to 20g		0.5 to 50g	
Packaging speed ※ <sup>2</sup>	300 to 400 pouches/min (film speed: 28 m/min)		200 to 600 pouches/min (film speed: 42 m/min)	
Pouch size	Width: 30 to 90 mm (specified) Length: 40 to 90 mm (specified)		Width: 30 to 110 mm (specified) Length: 40 to 125 mm (specified)	
Machine dimensions	Approx. 2,500 (W) 750 (D) 1,950 (H) mm		Approx. 2,750 (W) 880 (D) 1,980 (H) mm	
Machine weight	Approx. 1,800 kg		Approx. 2,500 kg	
Power consumption	Approx. 5 to 7 kw		Approx. 6 to 8 kw	
Compressed air consumption	Approx. 0.5 MPa · 50 liter/min (ANR)			

※<sup>1</sup>Standard value for granulated sugar.

※<sup>2</sup>Specifications vary depending on the filling product, packaging material and pouch size.

※ C-type machines are also available without the cutter and automatic film splicer.

## ■ Main specifications of R-series G-type machines

Model	Small pouch machine		Large pouch machine	
	R-35G	R-36G	R-51G	R-52G
Print registration control	None	Provided	None	Provided
Filling capacity ※ <sup>1</sup> ※ <sup>2</sup>	0.5 to 20g		0.5 to 50g	
Packaging speed ※ <sup>2</sup>	300 to 400 pouches/min (film speed: 28 m/min)		200 to 600 pouches/min (film speed: 42 m/min)	
Pouch size	Width: 30 to 90 mm (specified) Length: 40 to 90 mm (specified)		Width: 30 to 110 mm (specified) Length: 40 to 125 mm (specified)	
Machine dimensions	Approx. 2,200 (W) 710 (D) 1,950 (H) mm		Approx. 2,500 (W) 830 (D) 1,980 (H) mm	
Machine weight	Approx. 1,500 kg		Approx. 2,000 kg	
Power consumption	Approx. 4 to 6 kw		Approx. 5 to 7 kw	
Compressed air consumption	Approx. 0.5 MPa · 50 liter/min (ANR)			

※<sup>1</sup>Standard value for granulated sugar.

※<sup>2</sup>Specifications vary depending on the filling product, packaging material and pouch size.

※ C-type machines are also available without the cutter and automatic film splicer.

## ■ Required installation space(R-51S,R-52S)

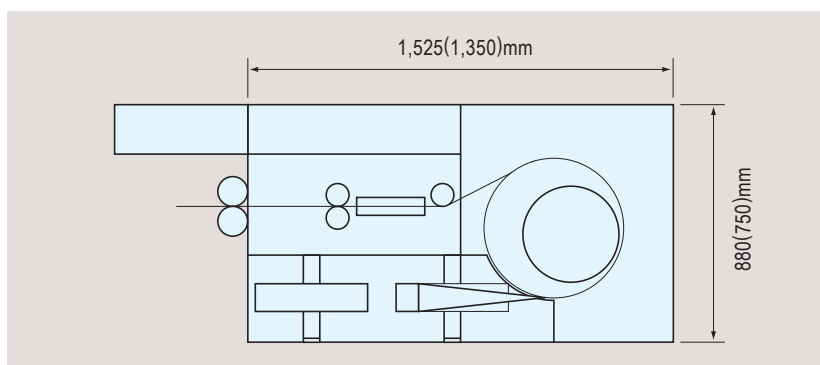

※Figures in parentheses ( ) indicate installation space required by the R-35S, R-36S models.

※This catalog lists standard specifications. Due to improvements in the equipment, specifications are subject to change without notice.

## ■ Application examples

Powdered soup, seasonings, granulated sugar, coffee, powdered cream, tea bags, food supplements, powdered/granulated pharmaceuticals, desiccants, oxygen absorbers, food additives, bath agents.

## ■ Product samples



## ■ Line configuration

R series + continuous pouch loader  
 R series + continuous pouch winder  
 R series + stacker + pouch filler  
 R series + stacker + flow wrapping machine  
 R series + stacker + cartoner  
 R series + stacker + banding unit  
 Various other lines can also be configured.

## ■ Film material and dimensions

- Heat-sealable laminated film
- Film roll outer diameter: 400 mm max., diameter of core paper roll: 76 mm

## ■ Standard equipment

- Print registration system (R-36S, R-52S, R-36G, R-52G)
- Touch panel(S type)
- Automatic film splicer
- Film end detector
- Joined tape detector
- Empty pouch detector
- Preheating bar open-status detector
- Automatic preheating bar operating system
- Heater disconnection detector
- Overload detector
- Safety cover with auto-stop
- Hopper level switch

## ■ Optional equipment

- Dust collector
- Counting and dividing unit
- Opening notch cutting unit(single notch)
- Code printing unit
- 4-side sealing unit
- Adjustable volumetric controller



**TOPACK CO.,LTD.**

15-10, Kamihigashi 6-chome Hirano-ku, Osaka 547-0002, Japan  
 Phone : 81-6-6792-7341 Fax : 81-6-6794-3074  
 URL : <http://www.topack.co.jp/>